

UM10321

75 W SSL1750 triac dimmable 230 V mains LED driver

Rev. 01 — 9 October 2009

User manual

Document information

Info	Content
Keywords	SSL 1750, PFC, LED driver, high power, triac, high power factor, mains dimmable
Abstract	User manual for the SSL1750 230 V(AC) mains dimmable 75 W, 1000 mA LED driver board.

Revision history

Rev	Date	Description
01	20091009	Initial release

Contact information

For more information, please visit: <http://www.nxp.com>

For sales office addresses, please send an email to: salesaddresses@nxp.com

1. Introduction

This SSL1750 board is a 75 W, 1000 mA current regulated, LED driver that is dimmable with standard mains triac dimmers. The board is using the NXP SSL1750 switched mode power supply with integrated power factor correction (PFC) and flyback controller. The circuitry for communication between both controllers is integrated and needs no adjustment. The PFC output power is on-time controlled for simplicity. It is not necessary to sense the phase of the mains voltage. The flyback output-power is current-mode controlled for good suppression of input-voltage ripple.

The board is very efficient, higher than 85 %, has a high power factor, above 0.95 over the whole voltage input range and the THD falls within the limits for class-C equipment. Making this board ideal for dimmable high power LED lighting systems.

The board has been optimized for triac-based dimmers. As different triac dimmers have different specifications the dimming performance of the reference board might vary based on the used dimmer. Transistor dimmers and other non-triac dimmers will not work with this board.

1.1 IC description

The SSL1750 is a Switched Mode Power Supply (SMPS) controller IC, suitable for driving LED applications from 25 W up to 250 W. For LED power requirements below 25 W the NXP SSL210x family is preferred.

The SSL1750 combines Power Factor Correction (PFC) and a flyback controller. Its high level of integration allows the design of a cost-effective high efficiency LED power supply with a low number of external components.

The special built-in green functions provide high efficiency at all power levels. This applies to quasi-resonant operation at high power levels, quasi-resonant operation with valley detection, as well as reduced frequency operation at lower power levels. At low power levels, the PFC switches over to burst mode control to maintain high efficiency. In burst mode, soft-start and soft-stop functions are added to eliminate audible noise.

During low power conditions, the flyback controller switches to frequency reduction mode and limits the peak current to 25 % of its maximum value. This will ensure high efficiency at low power while minimizing audible noise from the transformer.

The proprietary high voltage BCD800 process makes direct start-up possible from the rectified universal mains voltage in an effective and green way. A second low voltage Silicon On Insulator (SOI) IC is used for accurate, high speed protection functions and control.

The SSL1750 enables the design of highly efficient and reliable LED drivers at power requirements up to 250 W, it can be designed with a minimum number of external components.

2. Specification

The main specification is given in [Table 1](#)

Table 1. Specification for the SSL1750 dimmable board

Type	Value	Comment
AC line input voltage	230 V \pm 10 %	
DC Output current	1000 mA \pm 10 %	When not dimmed
Output Power	75 W \pm 10 %	When not dimmed
DC Output Voltage	56 V to 82 V	Depending on LED forward voltage.
Dimming range	100 mA to 1000 mA	Depending on dimmer.
Driver Efficiency	> 85 %	Over whole input voltage range. With 75 W load and no dimming
Power Factor	> 0.95	For 230 V (AC) \pm 10 % mains and no dimmer used

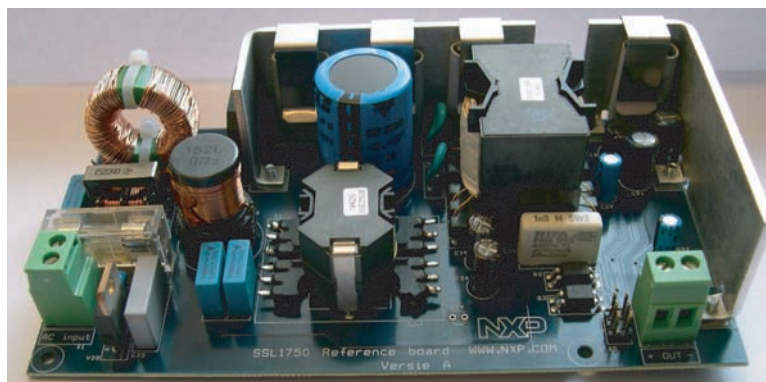

Fig 1. Photo of the dimmable 75 W LED driver board

3. Board connections

3.1 Input

On the AC input, connector X1, you can connect 230 V (AC) (\pm 10 %) 50 Hz. The mains can be connected to the board directly or via a triac dimmer. See [Section 5.4](#) for more details about the different dimmers.

3.2 Output

The anode of the LED strings should be connected to the '+' of connector X2. The cathode should be connected to the '-' of the same connector.

The board is designed to provide 1000 mA of current into a LED load. It is advised to use only one LED string. When more than one LED string is used, care must be taken to balance the current in each string to prevent one LED string having higher currents than other strings. In [Table 2](#) example configurations are listed of different LED loads.

The total forward voltage (V_F) of the LED string should not exceed the maximum output voltage of the board (see [Section 4.5.2](#)). A lower total V_F is allowed, as long as the output stays above the minimum output voltage (see [Section 4.5.1](#)).

Table 2. Example of LED configurations

Current per led string (mA)	LED strings	Number of LEDss per string	V_F (V)
330	3	24	3.15
500	2	23	3.25
1000	1	22	3.4

4. Functional description

The board is made around the SSL1750 IC. The SSL1750 includes a PFC and a flyback controller integrated in one SO-16 package.

The PFC boost the rectified mains voltage to 380 V, which is enough to have a excellent power factor up to 250 V (AC) input. The PFC output power is on-time controlled for simplicity. It is not necessary to sense the phase of the mains voltage. During low dimming levels the PFC will go into burst mode for higher efficiency.

The board act as a current source for the LED load. The board can be used with and without a dimmer. Without a dimmer the driver will supply 1000 mA of current. With a dimmer the current depends on the phase cut angle of the dimmer. The phase cut signal of a dimmer is converted into a reference voltage so that the phase cut signal determines the level of the output current. The output current is analog regulated which means that no Pulse With Modulation (PWM) is used.

A simplified functional application diagram is shown in [Figure 2](#). Besides the PFC and flyback, a bleeder, an output current regulation and a dimming phase-angle detection circuit are shown. The function of these circuits are explained in this chapter.

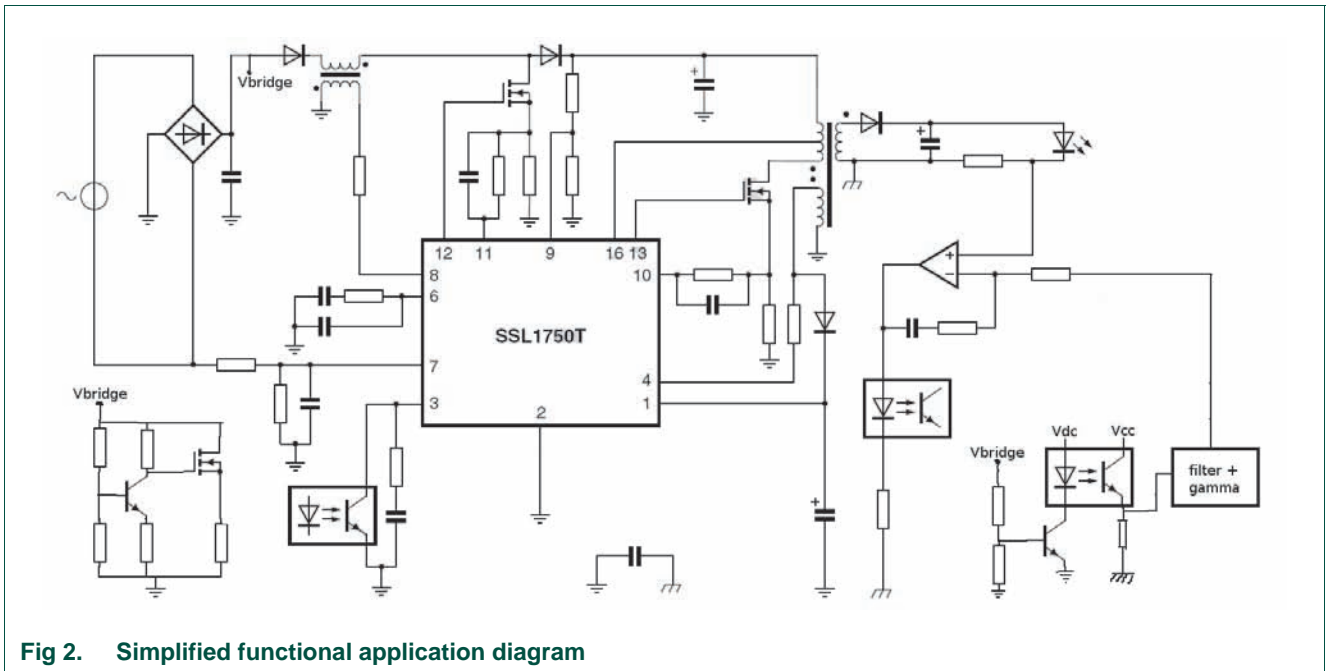

Fig 2. Simplified functional application diagram

4.1 Output current regulation

The output current is sensed with a (1 Ω) sense resistor and compared with a reference voltage. When no dimmer is connected, the reference voltage is such that a 1000 mA current will be supplied to the load on the output. When a dimmer is connected the reference voltage will change and thus the current, depending on the dimmer setting. The triac phase detection circuit will generate this reference voltage.

4.2 Triac phase detection circuit

The triac phase detection circuit, shown in [Figure 3](#), detects the phase angle of the triac dimmer to be able to control the LED current by changing the reference voltage for the current regulation loop. Also shown in [Figure 3](#), is the feedback loop to the flyback controller. A gamma curve is build-in to have a linear perceived-brightness response.

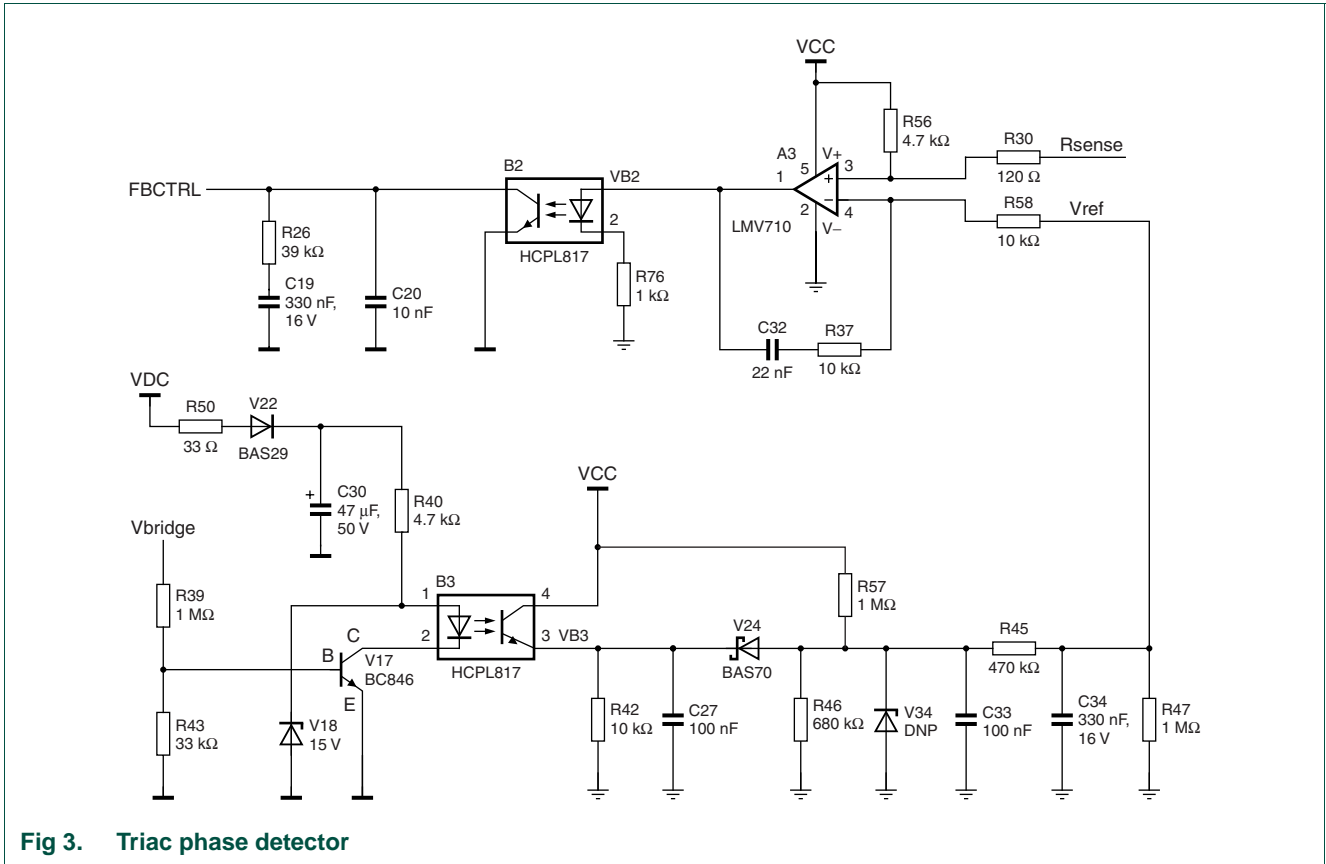

Fig 3. Triac phase detector

The dimmer signal is taken from the bridge rectifier (V_{bridge}). Transistor V17 will be conducting when a voltage on the mains is detected (> 50 V). When the triac dimmer is not conducting, transistor V17 will be off. Via the opto-coupler, B3, the capacitor C27 will be charged when the triac is on. When the dimmer is at 100 % conducting capacitor C27 is fully charged and diode V24 is not conducting. The resistive divider R57, R46, R45 and R47 will set the voltage level on the inverting input (pin 4) of the error amplifier A3. This voltage sets the maximum current. When the dimmer is set to less than 100 % conducting, the voltage on C27 drops and V24 conducts therefore the voltage on C33 drops. Resulting in a lower reference voltage for the current feedback loop. There the V-I curve of the diode (V24) is of logarithmic nature, the dimming curve will also be of logarithmic nature resulting in the desired gamma curve.

Diode V24 is chosen so that its forward voltage is low. This prevents a too high offset voltage needed at the non-inverting error amplifier input. Also the diode temperature behavior can influence the reference voltage. A low leakage Schottky type, like the NXP BAS70, is therefore preferable.

The error amplifier is build with operational amplifier A3. It compares the input sense voltage measured across the sense resistors (R66, R70, R72, R73) with the reference voltage. An opto-coupler is directly connected to the flyback control input FBCTRL to control the flyback frequency and mode.

The resistive divider formed by R30 and R65 sets an offset voltage on the current sense input. This makes sure that the load current can be controlled down to zero. The offset voltage corresponds with the minimum voltage present at the inverting input of the error amplifier when the dimmer conducting phase is set to maximum.

The power supply for error amplifier A3, shown in [Figure 4](#), is formed by use of an accurate reference voltage (TL431).

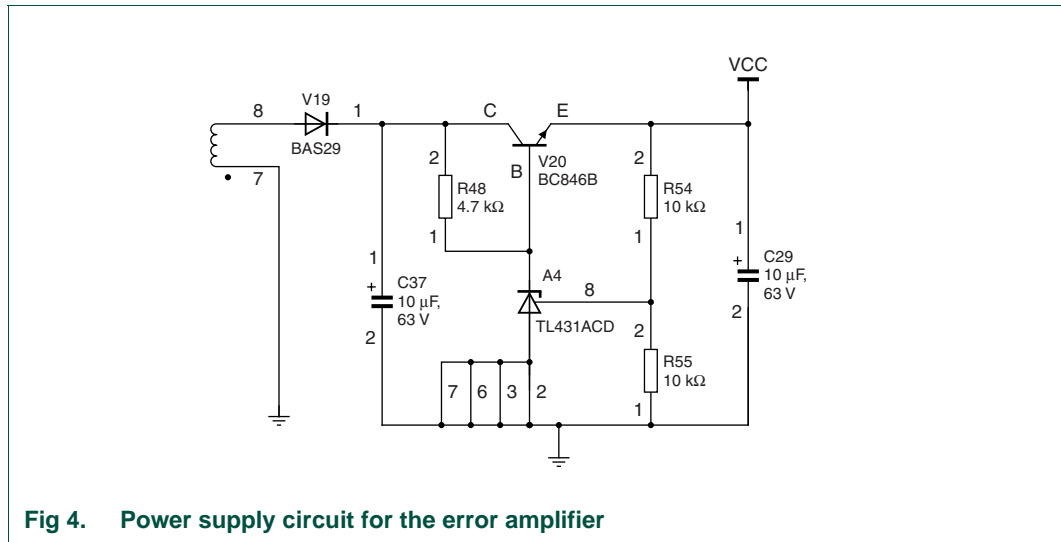

Fig 4. Power supply circuit for the error amplifier

4.3 Bleeder

To be able to work with a large range of dimmers a bleeder circuit is included on the board to provide a load for the dimmer to reset the dimmer timer and provide latch current for the dimmer triac.

In [Figure 5](#) the bleeder circuit diagram is shown. The FET, V28, operates as a current source. The current, $I_{bleeder}$, through R65 depends on the gate voltage which is set by the zener diode:

$$I_{bleeder} = \frac{V_{zener} - V_{th}}{R_{65}} = \frac{8.2 - 4.5}{33} = 112mA \tag{1}$$

The bleeder current will only flow when the bridge voltage V_{bridge} is below the level set by R59, R102, R107, R61 and V_{BE} of transistor V29.

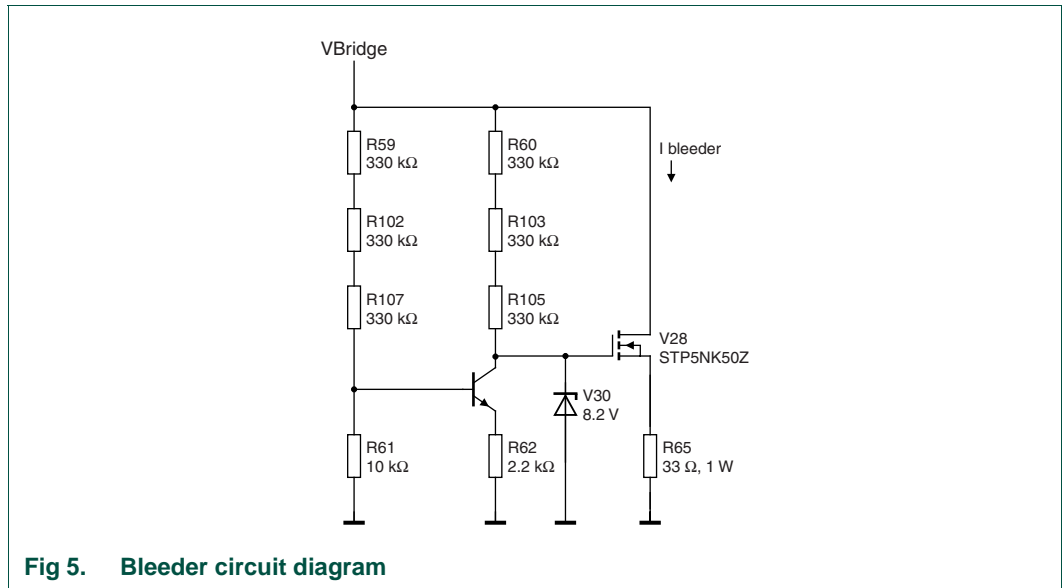

Fig 5. Bleeder circuit diagram

4.4 Flyback shut down circuit

At the lowest dimming settings the average input voltage is too low for the PFC to operate. The PFC-converter turns off and as a consequence the SSL1750 chip enters in the start up sequence. This causes interruptions in the output current, which are visible as flicker in the LED's.

Figure 6 shows the circuit used to switch off the flyback controller to prevent flickering dimming when the input voltage is too low.

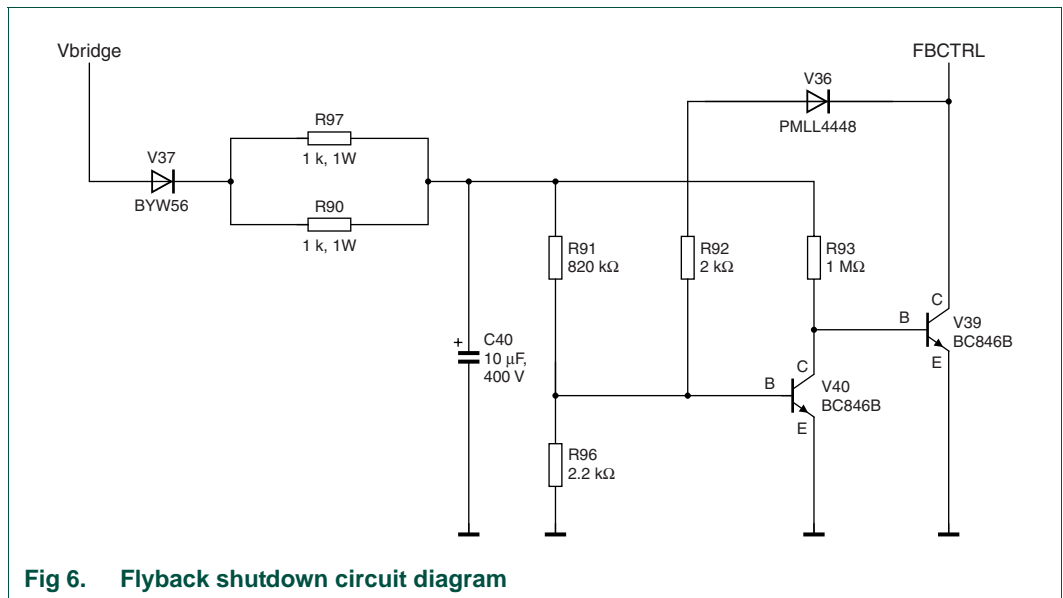

Fig 6. Flyback shutdown circuit diagram

Transistor V39 will pull FBCTRL to ground when the mains input voltage is below the lower trip level, causing the flyback to switch off. The input voltage from the bridge rectifier is detected by V37 and C40. The circuit inhibits an hysteresis. The hysteresis prevents the LED-driver from oscillating. The combination of R96 and R91 determines the lower trip level, V36 and R96 in parallel combined with R91 determines the higher trip level.

The lower trip level must be chosen in such a way that it corresponds with the level of the AC input voltage (output of the dimmer) just slightly above the point at which the PFC-converter turns off.

The higher trip level must be chosen in such a way that the FBCTRL level is open just below the minimum AC input voltage so that the driver is able to switch on under all allowed mains conditions.

The levels can be calculated as shown in [Equation 2](#): and [Equation 3](#)

$$V_{low(RMS)} = \frac{I}{\sqrt{2}} \times V_{BE} \times \frac{R_{91} + R_{96}}{R_{96}} \quad (2)$$

$$V_{high(RMS)} = \frac{I}{\sqrt{2}} \left(V_{BE} \cdot \frac{R_{91}}{R_{96}} + (V_{BE} - V_F) \cdot \frac{R_{91}}{R_{92}} + V_{BE} \right) \quad (3)$$

Where:

$$V_{BE} = 0.63 \text{ V}$$

$$V_F = 0.56 \text{ V}$$

The board is set at $V_{low} = 165 \text{ V RMS}$ and $V_{high} = 185 \text{ V RMS}$.

Due to voltage spikes, from switching-on the triac during dimming, the actual point could differ in some cases. Decreasing the value of capacitor C40 may help to reduce this effect.

4.5 Protections

The board and IC have several protections. In the following sections the main protections are mentioned. For details on protections in the IC please see the data sheet of the SSL1750 IC.

4.5.1 Output under voltage protection

The output under voltage is detected by the $V_{th(UVLO)}$ on the VCC pin. When the VCC level falls below the $V_{th(UVLO)}$ level of 15 V ($\pm 1 \text{ V}$) the flyback will be switch off. The VCC level depends on the output voltage. Therefore the protection will kick-in when the total forward voltage of the LED load is below $N_s/N_{aux} \times V_{th(UVLO)}$. Where N_s is the number of secondary turns and N_{aux} is the number of auxiliary turns of the transformer.

$$V_{o(UVLO)} = \frac{N_s}{N_{aux}} \times V_{th(UVLO)} \quad (4)$$

$$V_{o(UVLO)} = \frac{28}{8} \times 15 = 52.5V(typ) \quad (5)$$

$$V_{o(UVLO)} = \frac{28}{8} \times 14 = 49V(min) \quad (6)$$

$$V_{o(UVLO)} = \frac{28}{8} \times 16 = 56V(max) \quad (7)$$

Resulting in a minimum total forward voltage of the LED load to be 56 V.

4.5.2 Output over voltage protection

The output Over Voltage Protection (OVP) is provided by detecting the output voltage by the FBAUX pin. The FBAUX pin is connected via R_{FBAUX} to the auxiliary winding.

$$V_{o(ovp)} = \frac{N_s}{N_{aux}} (I_{ovp(FBAUX)} \times R_{FBAUX} + V_{clamp(FBAUX)}) \quad (8)$$

$$V_{o(ovp)} = \frac{N_s}{N_{aux}} (300\mu \times 82K + 0.7) = 88.6V(typ) \quad (9)$$

$$V_{o(ovp)} = \frac{N_s}{N_{aux}} (279\mu \times 82K + 0.7) = 82.5V(min) \quad (10)$$

$$V_{o(ovp)} = \frac{N_s}{N_{aux}} (321\mu \times 82K + 0.7) = 94.6V(max) \quad (11)$$

Where N_s is the number of secondary turns and N_{aux} is the number of auxiliary turns of the transformer. The value of R_{FBAUX} can be adjusted to the turns ratio of the transformer, thus making an accurate OVP detection possible.

To restart after an over voltage event, interrupt the mains to reset the internal latch.

4.5.3 PFC bus voltage protection

In case of an over voltage on the PFC bus, the PFC-controller will stop operating.

4.5.4 Temperature protection

The IC does have an internal temperature protection. When the internal temperature is above typical 140 °C the IC switches off to protect itself and the application.

A Negative Temperature Coefficient (NTC) device could be placed on the board, which should be connected to the latch pin, to shutdown the circuit if the ambient temperature is too high.

5. Measurements

5.1 Power Factor Correction (PFC)

Due to the integrated PFC controller the board will have a power factor above 0.95 for mains of 230 V (AC) $\pm 10\%$. [Table 3](#) gives the actual values. Measurements were executed under full load (75 W).

Table 3. Power factor versus mains voltage (50 Hz mains)

Mains V (AC) RMS	Power factor
207	0.979
220	0.975
230	0.971
240	0.965
245	0.960
250	0.956
253	0.957

5.2 Efficiency

Without a dimmer, the board can reach an efficiency of 85 % with 230 V (AC) ± 10 % while delivering 75 W of output power.

The efficiency of the board varies with the dimming level. Measurements with 3 different dimmers showed efficiency from 55 % at the lowest dimming position, up to 85 % at full power. This includes the losses in the dimmer

5.3 Harmonic currents

The harmonic currents measured on the board are listed in [Table 4](#). The harmonic currents for this board are below the limits of the Class-C of IEC 61000-3-2.

Table 4. Harmonic currents

Harmonic order	Maximum permissible harmonic percentage of fundamental current	Measured current [A]	Measured percentage
1	-	0.368	-
3	30 x PF (= 28.7 %)	0.100	27.1 %
5	10 %	0.013	3.7 %
7	7 %	0.014	3.9 %
9	5 %	0.006	1.6 %

Remark: Measurement conditions: $V_1 = 231 V_{pac}$; $P_1 = 85 W$; $I = 0.384 A$; $pf = 0.956$

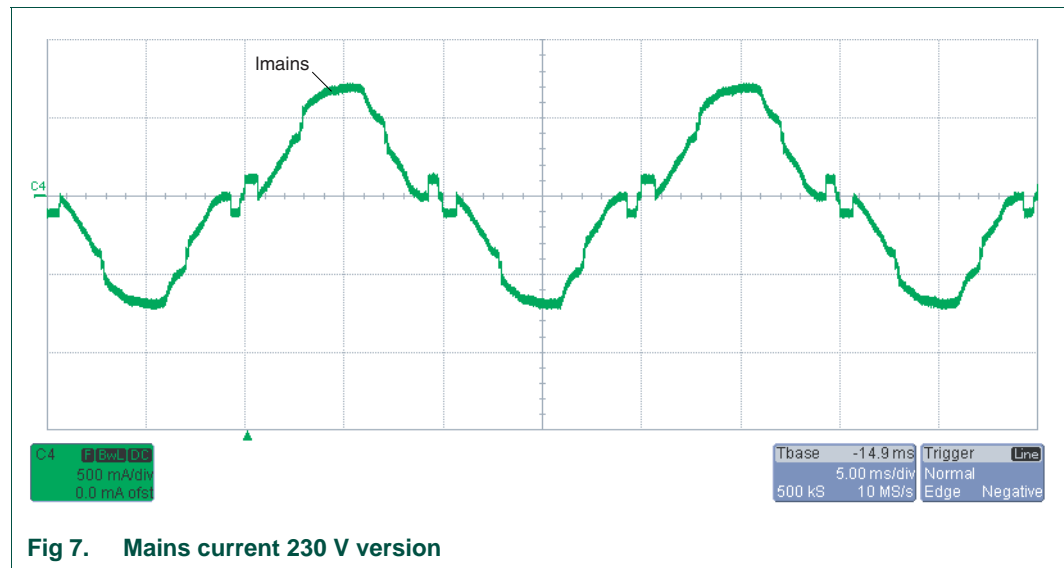

Fig 7. Mains current 230 V version

5.4 Dimming

The board has been optimized for triac-based dimmers. Several triac dimmers have been tested by NXP Semiconductors. As different dimmers have different specifications the dimming performance of the reference board might vary based on the used dimmer. Non-triac dimmers, like transistor dimmers or so called electronic dimmers, are not tested with this board.

Remark: Non-triac dimmers, like transistor dimmers or so called electronic dimmers, have not been tested with this board

5.4.1 Dimming curve

Measurement data of the dimming curve, as described in [Section 4.2](#), is shown in [Figure 8](#)

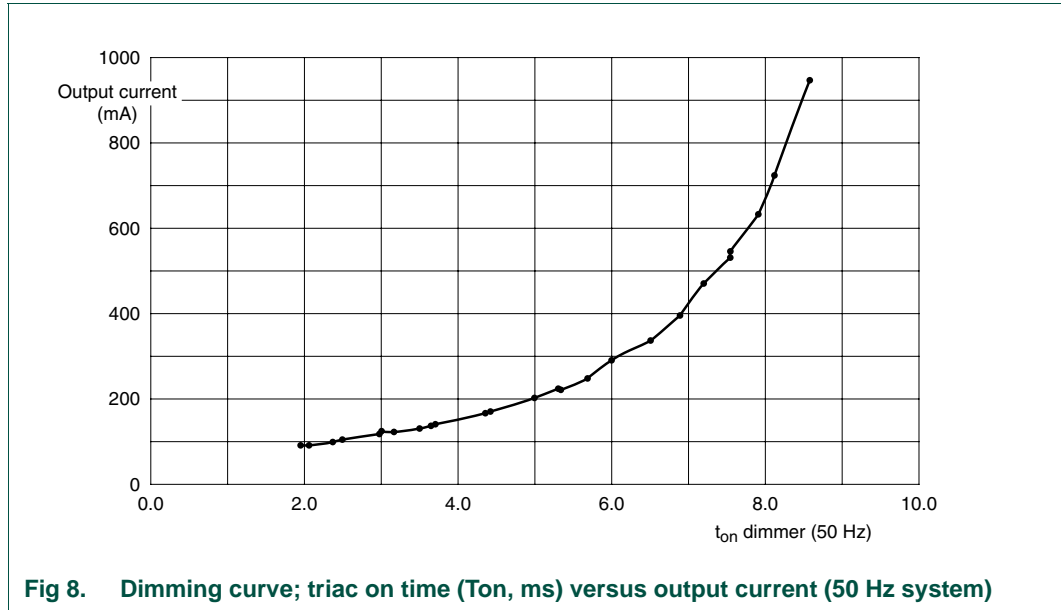

When the dimming level is getting below a certain point ($T_{on} \sim 2$ ms), the input voltage seen by the board, will be too low and the board will switch off the flyback.

6. Circuit diagram

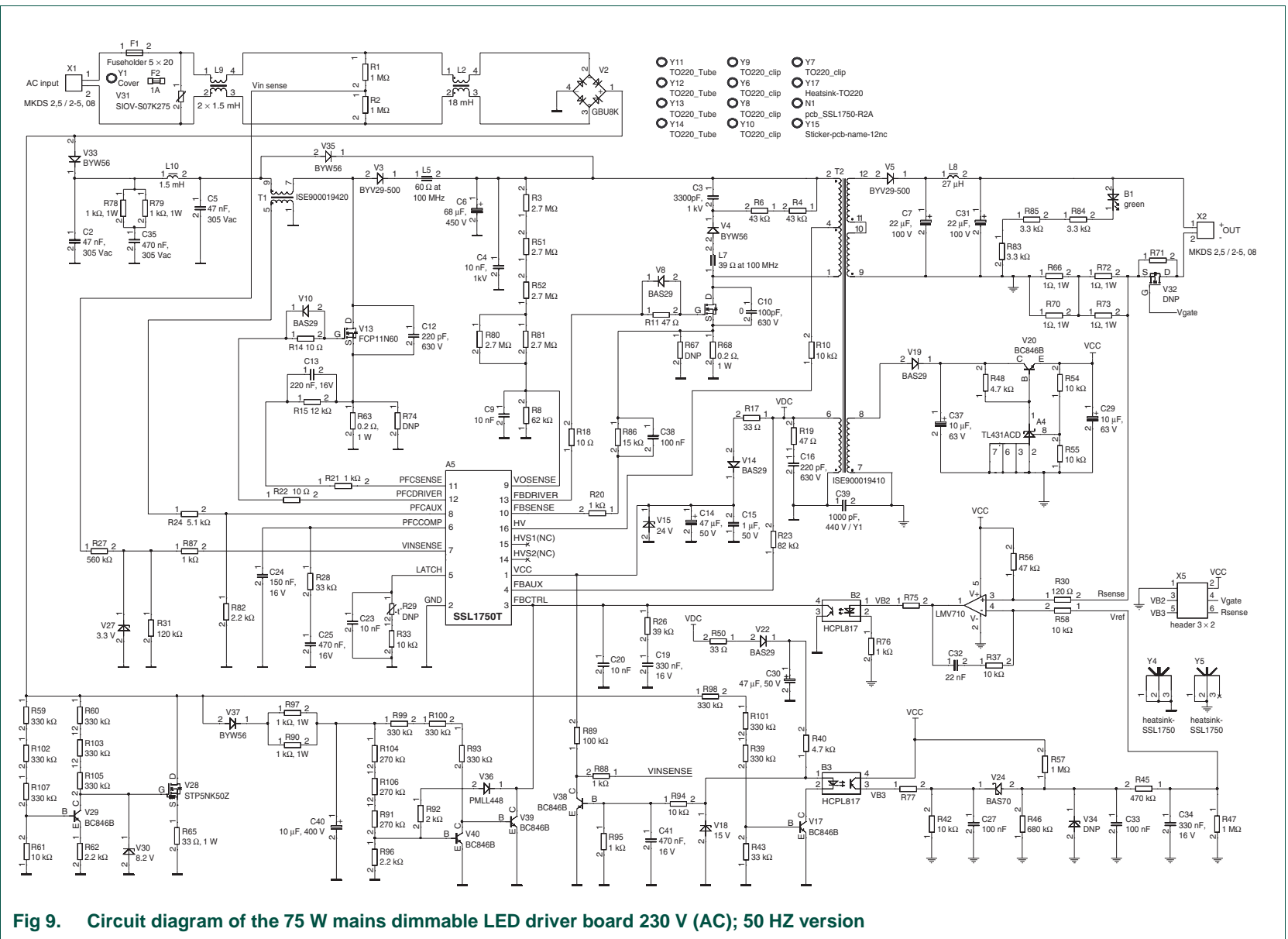

Fig 9. Circuit diagram of the 75 W mains dimmable LED driver board 230 V (AC); 50 HZ version

7. PCB silk screen and layout

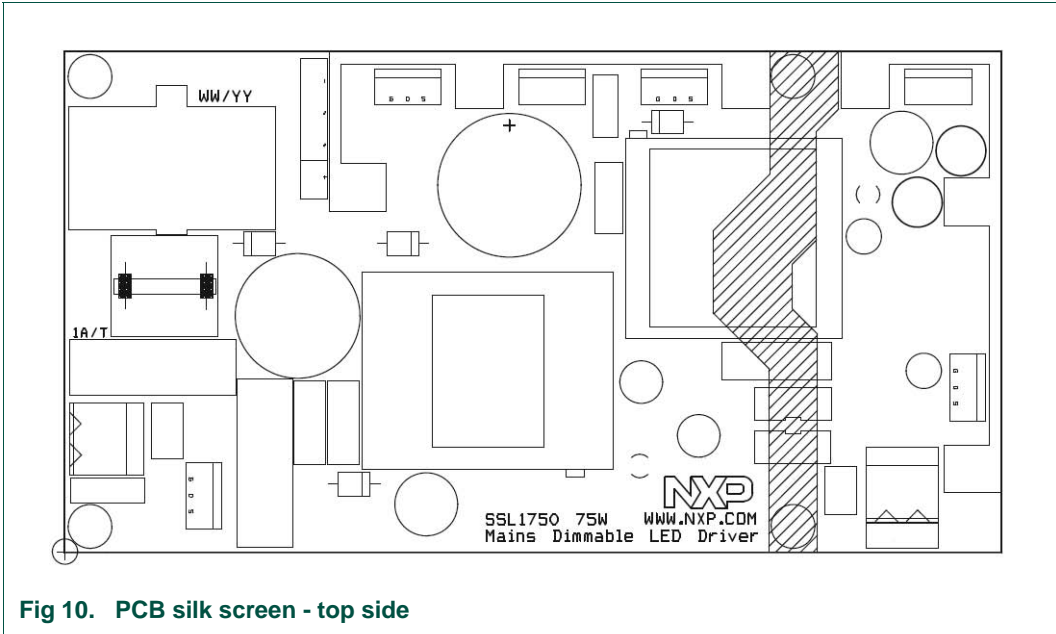

Fig 10. PCB silk screen - top side

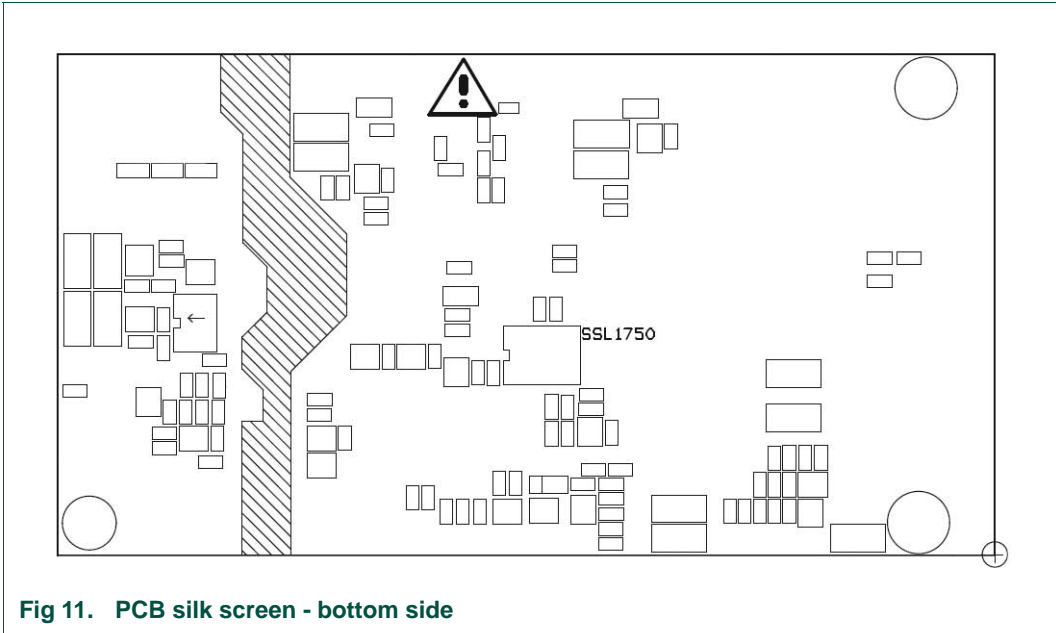

Fig 11. PCB silk screen - bottom side

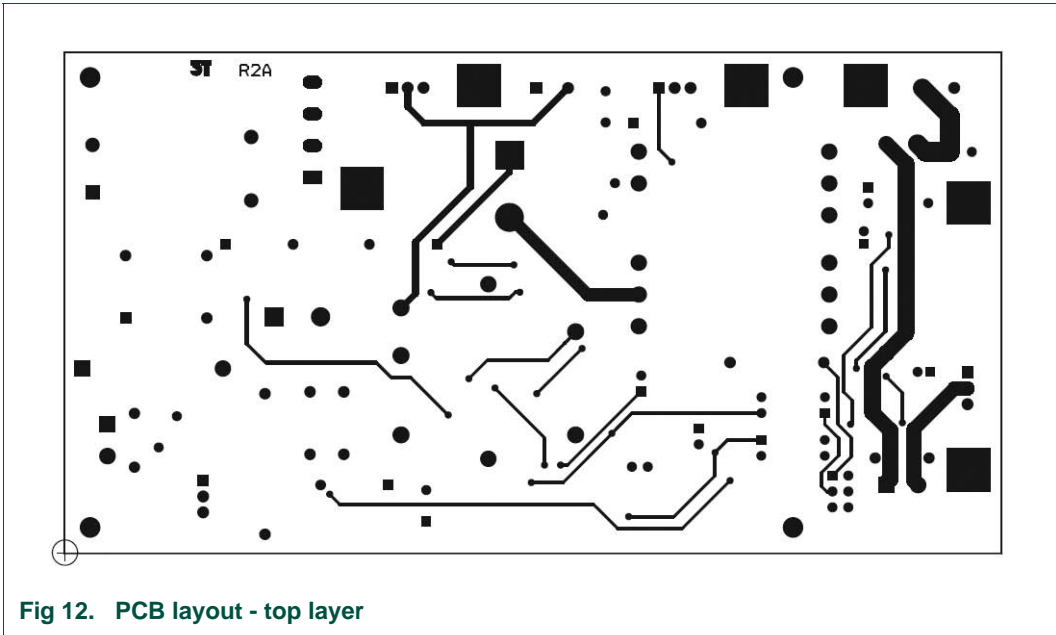

Fig 12. PCB layout - top layer

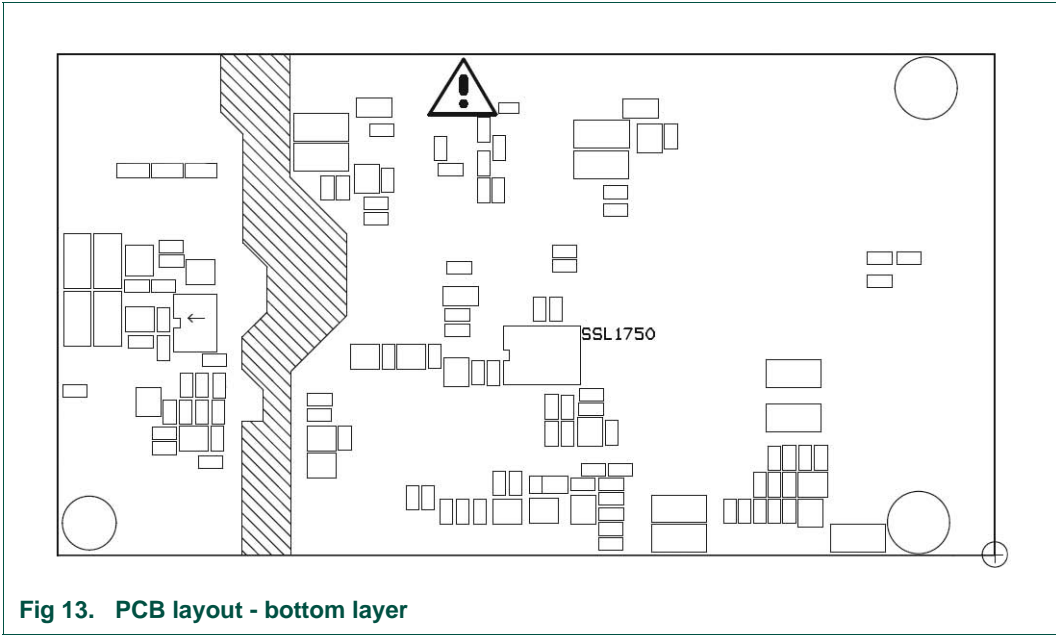

Fig 13. PCB layout - bottom layer

8. Transformer specification

8.1 PFC

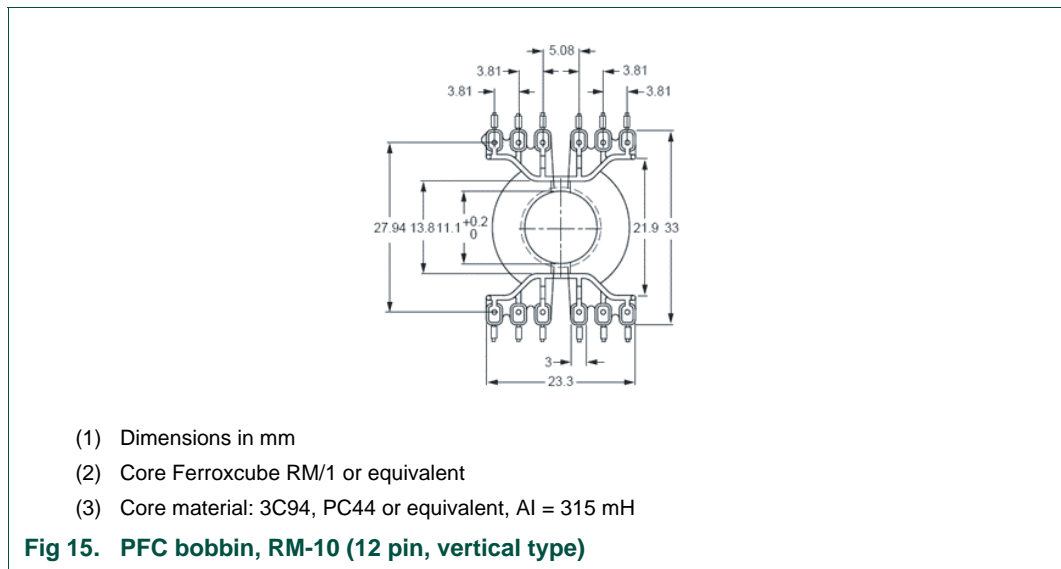
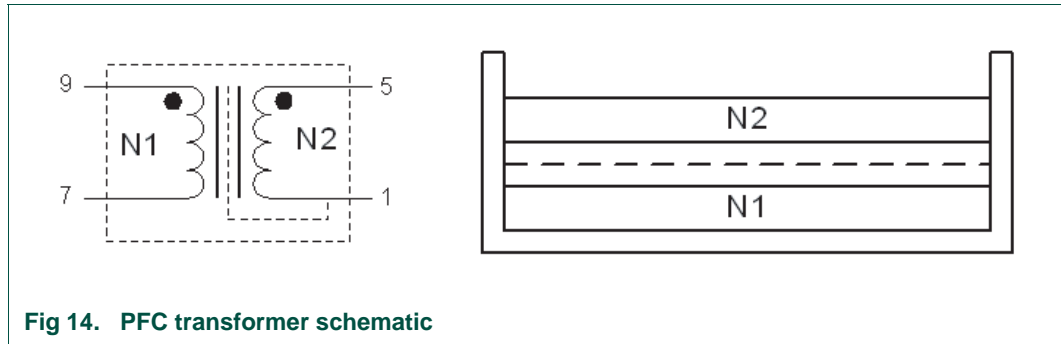

Table 5. PFC transformer winding specifications 230 V version

No.	Pin		Wire	Turns	Winding method	Ignition Turns	Width
	Start	Finish					
N1	9	7	0.1Φ*30	40	Center		
I1						1	10 mm
N2	5	1	0.22Φ*2	2	Center		
I2						1	10 mm
S1		1	0.05t*10 mm	1	Center		
I3						1	10 mm

Table 6. PFC transformer electrical characteristics 230 V version

	Pin	Specification	Remark
Inductance	9 - 7	500 μH ± 10 %	60 kHz, 1 V
Leakage inductance	9-7	N/A	

8.2 Flyback

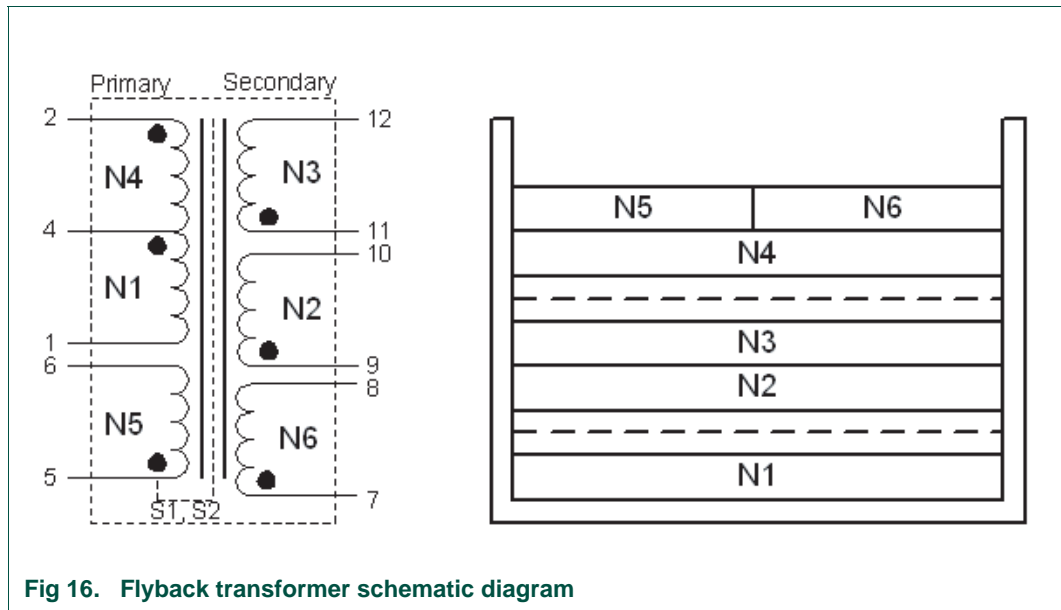

Fig 16. Flyback transformer schematic diagram

Table 7. Flyback winding specification

No.	Pin		Wire	Turns	Winding method	Insulation	
	Start	Finish				Ignition Turns	Width
N1	4	1	-	20	Center	-	-
I1	-	-	-	-	-	1	10 mm
S1	-	5	0.025t*10 mm	1	Center	-	-
I2	-	-	-	-	-	1	10 mm
N2	9	10	-	14	Center	-	-
N3	11	12	-	14	Center	-	-
I3	-	-	-	-	-	1	10 mm
S2	-	5	0.025t*10 mm	1	Center	-	-
I4	-	-	-	-	-	1	10 mm
N4	2	4	-	20	Center	-	-
I5	-	-	-	-	-	1	10 mm
N5	5	6	0.25Φ*2	8	Center	-	-
N6	7	8	0.25Φ*2	8	Center	-	-
I6	-	-	-	-	-	2	10 mm

[1] Pin 3 cut off

[2] N2, N3 and N6, and N6, use triple insulated wire

[3] Use maximum diameter or parallel wires for maximal fill

Table 8. Electrical characteristics

	Pin	Specification	Remark
Inductance	1-2	650 μ H \pm 10 %	60 kHz, 1 V
Leakage inductance	1-2	< 5 μ H	2 nd all short

Flyback core and bobbin

Core: PQ-3220

Core material: 3C94, PC44 or equivalent (Al = 400 nH)

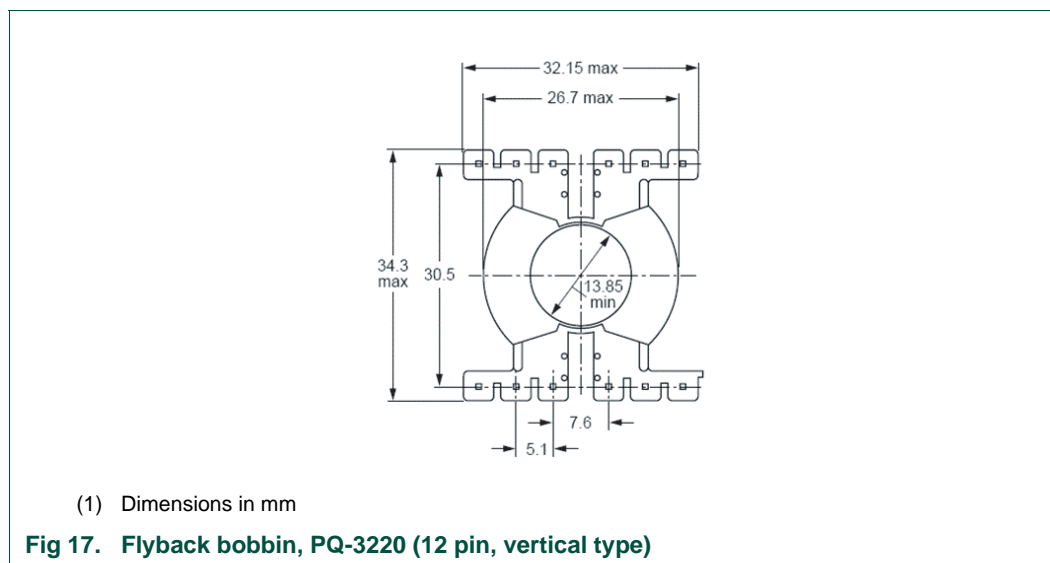

9. Bill Of Materials (BOM)

Table 9. Bill of material SSL1750 75 W mains dimmable board 230 V version

Reference	Manuf.	Value	Description	Pkg. type
A3		LMV710	operational amp; single; 2.7 V to 5.5 V SS; RR-i/o; 3 mVos [A48A]	SOT23-5
A4		TL431ACD	voltage reference programmable shunt; 2.5 V to 36 V; SO8	SO8
A5	NXP	SSL1750T	SMPS control IC for LED drivers	SO16
B1		green	LED 3 mm green diffused tinted; 6 mcd at 10 mA	LED3_V
B2, B3		HCPL817	opto-coupler single OC 5000 V; CTR = 50..600 %	DIP4W
C2, C5		47 nF; 305 V (AC)	capacitor; MKP Class X2; pitch =10 mm 20 %	CFILM10MMx5
C3		3300 pF; 1 kV	capacitor ceramic high voltage; Class 2	CDISC
C4		10 n F; 1 kV	capacitor ceramic high voltage	
C6		68 μ F; 450 V	capacitor electrolytic radial 450 V; 85c 20 %	CPRAD
C7, C31		22 μ F; 100 V	capacitor electrolytic radial 8 mm x 11.5 mm p 3.5 mm; 105 °C; 0.68 ESR 20 %	CPRAD
C9 ,C20, C23		10 nF	capacitor ceramic X7R; 50 V; 10 %	C0805
C10		100 pF; 630 V	capacitor ceramic C0G; 630 V; 5 %	C1206

Table 9. Bill of material SSL1750 75 W mains dimmable board 230 V version ...continued

Reference	Manuf.	Value	Description	Pkg. type
C12, C16		220 pF / 630 V	capacitor ceramic C0G; 630 V; 5 %	C1206
C13		220 nF; 16 V	capacitor ceramic X7R;16 V; 10 %	C0805
C14, C30		47 μ F; 50 V	capacitor electrolytic radial 50 V; esr = 0.65 Ω ; 105 $^{\circ}$ C 20 %; d = 6.3; h = 11 p2.5	CPRAD
C15		1 μ F; 50 V	capacitor ceramic X5R; 50 V, 20 %	C0805
C19, C34		330 nF; 16 V	capacitor ceramic X7R; 16 V, 10 %	C0805
C24		150 nF/ 16 V	capacitor ceramic X7R; 16 V, 10 %	C0805
C25, C41		470 nF / 16 V	capacitor ceramic X7R;16 V 10 %	C0805
C27, C33, C38		100 nF	capacitor ceramic X7R; 50 V, 10 %	C0805
C29, C37		10 μ F; 63 V	capacitor electrolytic radial, 63 V 20 %; 5 mm x 11 mm x 2 mm	CPRAD
C32		22 nF	capacitor ceramic X7R; 50 V, 10 %	C0805
C35		470 nF; 305 V (AC)	capacitor, MKP; Class X2; pitch = 22 mm X 5 mm 20 %	CFILM22.5 m x 8.5 mm
C39		1000 pF; 440 V; Y1	capacitor ceramic high voltage Y1	CDISC
C40		10 μ F; 400 V	capacitor electrolytic radial; 10 mm x 20 mm x 5 mm 20 % (ED-serie)	CPRAD
F1		fuse holder 5 x 20	fuse holder for 5 mm x 20 mm	FUSE_H_20x5
F2		1 A	fuse 5 mm x 20 mm; time lag	5 mm x 20 mm
L2		18 mH	inductor choke common; I _r =1 A; R = 640 m Ω	TH_CM_IND
L5		60 Ω at100 MHz	inductor Solid Chip Ferrite HF smd	L0603
L7		39 Ω at 100 MHz	inductor Solid Chip Ferrite HF smd	L0805
L8		27 μ H	inductor Choke; I _r = 1.6 A; R = 58 m Ω	LRAD5mm10
L9		2 x 1.5 mH	inductor choke CM; I _r = 2 A; R = 150 m Ω	L_CM-TH
L10		1.5 mH	inductor Choke; I _r = 850 mA; R = 580 m Ω	LRAD7.5mm20
R1, R2, R39, R47, R57, R59, R60, R93		1 M Ω	resistor 1 %; 0.125 W; 100 ppm RC12H	R0805
R3, R51, R52, R80, R81		2.7 M Ω	resistor 1 %; 0.125 W; 100 ppm RC12H	R0805
R4, R6		43 k Ω	resistor 1 %; 0.125 W; 100 ppm RC12H	R0805
R8		62 k Ω	resistor 1 %; 0.125 W; 100 ppm RC12H	R0805
R10,, R33, R37 R42, R54, R55, R58, R61, R94		10 k Ω	resistor 1 %; 0.125 W; 100 ppm RC12H	R0805
R11, R19		47 Ω	resistor 1 %; 0.125 W; 100 ppm RC12H	R0805
R14, R18, R22		10.0 Ω	resistor 1 %; 0.125 W; 100 ppm RC12H	R0805
R15		12 k Ω	resistor 1 %; 0.125 W; 100 ppm RC12H	R0805
R17, R50		10.0 Ω	resistor 1 %; 0.125 W; 100 ppm RC12H	R0805
R20, R21, R76, R87, R88, R95		1 k Ω	resistor 1 %; 0.125 W; 100 ppm RC12H	R0805

Table 9. Bill of material SSL1750 75 W mains dimmable board 230 V version ...continued

Reference	Manuf.	Value	Description	Pkg. type
R23		82 k Ω	resistor 1 %; 0.125 W; 100 ppm RC12H	R0805
R24		5.1 k Ω	resistor 1 %; 0.125 W; 100 ppm RC12H	R0805
R26		39 k Ω	resistor 1 %; 0.125 W; 100 ppm RC12H	R0805
R27		560 k Ω	resistor 1 %; 0.125 W; 100 ppm RC12H	R0805
R28, R43		33 k Ω	resistor 1 %; 0.125 W; 100 ppm RC12H	R0805
R29		DNP	-	
R30		120 Ω	resistor 1 %; 0.125 W; 100 ppm RC12H	R0805
R31		120 k Ω	resistor 1 %; 0.125 W; 100 ppm RC12H	R0805
R40, R48, R56		4.7 k Ω	resistor 1 %; 0.125 W; 100 ppm RC12H	R0805
R45		470 k Ω	resistor 1 %; 0.125 W; 100 ppm RC12H	R0805
R46		680 k Ω	resistor 1 %; 0.125 W; 100 ppm RC12H	R0805
R62, R82, R96		2.2 k Ω	resistor 1 %; 0.125 W; 100 ppm RC12H	R0805
R63, R68		0.2 Ω ; 1 W	resistor metal Strip 1 %; 1 W	R2512
R65		33 Ω ; 1 W	resistor Thick Film 1 %; 1 W 200 V	R2512
R66, R70, R72, R73		1 Ω ; 1 W	resistor Thick Film 1 % 1 W 200 V	R2512
R67		DNP	-	
R71, R75, R77		0 Ω	resistor R0805 0E jumper	R0805
R74		TBD	-	
R78, R79, R90, R97		1 k Ω / 1 W	resistor Thick Film 1%; 1 W	R2512
R83, R84, R85		3.3 k Ω	resistor 1 %; 0.250 W; 100 ppm RC02H	R1206
R86		15 k Ω	resistor 1 %; 0.125 W; 100 ppm RC12H	R0805
R89		100 k Ω	resistor 1 %; 0.125 W; 100 ppm RC12H	R0805
R91		820 k Ω	resistor 1 %; 0.125 W; 100 ppm RC12H	R0805
R92		2 k Ω	resistor 1 %; 0.125 W; 100 ppm RC12H	R0805
T1			coil PFC RM 10 custom-made	RM10
T2			transformer PQ-32/20 custom-made	PQ-3220
V2		GBU8K	bridge 800 V; 8 A TH	SIL_BRIDGE
V3, V5	NXP	BYV29-500	diode, ultra fast 500 V; 9 A	TO220AC
V4, V33, V35, V37		BYW56	diode, avalanche 1000 V; 2 A	SOD57
V8, V10, V14, V19, V22	NXP	BAS29	diode, 50 ns; 90 V; 250 mA	SOT23
V9, V13		FCP11N60	FET MOS N-ch 650 V; 11 A; 0,32E	TO220
V15	NXP	BZX84C24	Zener 24 V; 250 mW, 5 % [Y9t/Y9p/Y9W]	SOT23
V17, V20, V29, V38, V39, V40	NXP	BC846B	NPN transistor 65 V; 250 mW; smd{1Bp/1Bt}	SOT23
V18	NXP	BZX84C15	Zener 15 V; 250 mW, 5 %; [Y4t/Y4p/Y4W]	SOT23
V24	NXP	BAS70	diode Schottky $V_f=70$ V; $V_f = 410$ mV, $I_f = 70$ mA	SOT23
V27	NXP	BZX84C3V3	diode Zener 3.3 V; 250 mW, 5 % [z14/pB1/tB1/WB1]	SOT23
V28		STP5NK50Z	FET N-ch; 500 V; 4.4 A; 1.22E; zener protected	TO220
V30	NXP	BZX84C8V2	diode Zener 8.2 V; 250 mW; [Z7t/Z7p/Z7W]	SOT23

Table 9. Bill of material SSL1750 75 W mains dimmable board 230 V version ...continued

Reference	Manuf.	Value	Description	Pkg. type
V31		SIOV-S07K275	varistor; disk 275 V; d = 9, p = 5 mm	Rdisc9mm
V32		DNP	-	
V34		DNP	-	
V36	NXP	PMLL4448	diode; low drop 75 V; 200 mA; High speed	SOD80
X1, X2		MKDS 2,5 / 2-5,08	terminal block (screw) 2-p; p = 2e; 2.5 mm ²	MKDS
X5		header 3x2	header dual straight gold; p = 2.54; Lpin = 5.80 (strip72)	6/72 DROW72
Y1		cover	fuse holder cover for 5 mm x 20 mm	N.A.

10. Legal information

10.1 Definitions

Draft — The document is a draft version only. The content is still under internal review and subject to formal approval, which may result in modifications or additions. NXP Semiconductors does not give any representations or warranties as to the accuracy or completeness of information included herein and shall have no liability for the consequences of use of such information.

10.2 Disclaimers

General — Information in this document is believed to be accurate and reliable. However, NXP Semiconductors does not give any representations or warranties, expressed or implied, as to the accuracy or completeness of such information and shall have no liability for the consequences of use of such information.

Right to make changes — NXP Semiconductors reserves the right to make changes to information published in this document, including without limitation specifications and product descriptions, at any time and without notice. This document supersedes and replaces all information supplied prior to the publication hereof.

Suitability for use — NXP Semiconductors products are not designed, authorized or warranted to be suitable for use in medical, military, aircraft, space or life support equipment, nor in applications where failure or malfunction of a NXP Semiconductors product can reasonably be expected to result in personal injury, death or severe property or environmental damage. NXP Semiconductors accepts no liability for inclusion and/or use of NXP Semiconductors products in such equipment or applications and therefore such inclusion and/or use is at the customer's own risk.

Applications — Applications that are described herein for any of these products are for illustrative purposes only. NXP Semiconductors makes no representation or warranty that such applications will be suitable for the specified use without further testing or modification.

Export control — This document as well as the item(s) described herein may be subject to export control regulations. Export might require a prior authorization from national authorities.

10.3 Trademarks

Notice: All referenced brands, product names, service names and trademarks are the property of their respective owners.

11. Contents

1	Introduction	3
1.1	IC description	3
2	Specification	4
3	Board connections	4
3.1	Input	4
3.2	Output	4
4	Functional description	5
4.1	Output current regulation	6
4.2	Triac phase detection circuit	6
4.3	Bleeder	8
4.4	Flyback shut down circuit	9
4.5	Protections	10
4.5.1	Output under voltage protection	10
4.5.2	Output over voltage protection	11
4.5.3	PFC bus voltage protection	11
4.5.4	Temperature protection	11
5	Measurements	11
5.1	Power Factor Correction (PFC)	11
5.2	Efficiency	12
5.3	Harmonic currents	12
5.4	Dimming	13
5.4.1	Dimming curve	13
6	Circuit diagram	14
7	PCB silk screen and layout	15
8	Transformer specification	17
8.1	PFC	17
8.2	Flyback	18
9	Bill Of Materials (BOM)	19
10	Legal information	23
10.1	Definitions	23
10.2	Disclaimers	23
10.3	Trademarks	23
11	Contents	24

Please be aware that important notices concerning this document and the product(s) described herein, have been included in section 'Legal information'.

founded by

PHILIPS

© NXP B.V. 2009.

All rights reserved.

For more information, please visit: <http://www.nxp.com>

For sales office addresses, please send an email to: salesaddresses@nxp.com

Date of release: 9 October 2009

Document identifier: UM10321_1